

SIENA MKIII 750 GF2L AND GF2R*

APPLIANCE DIMENSIONS

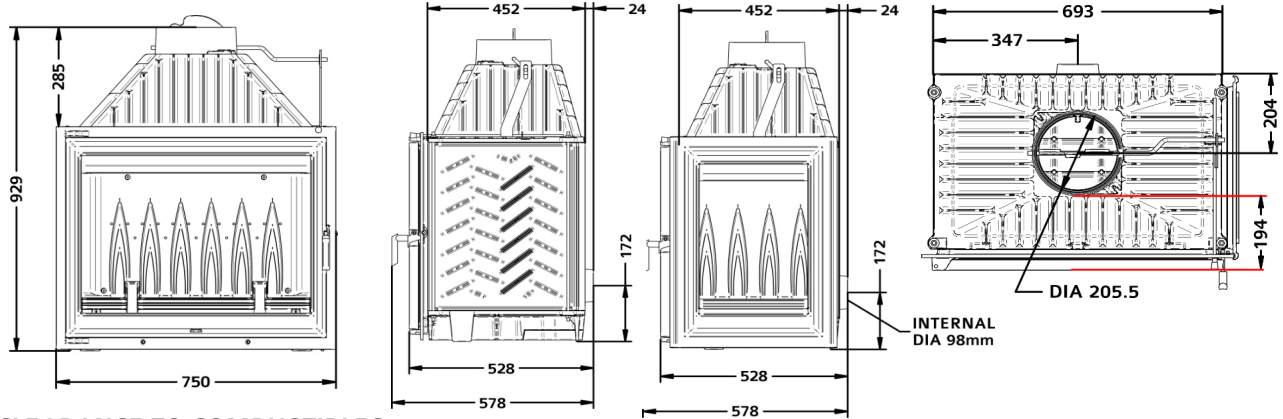

CLEARANCE TO COMBUSTIBLES

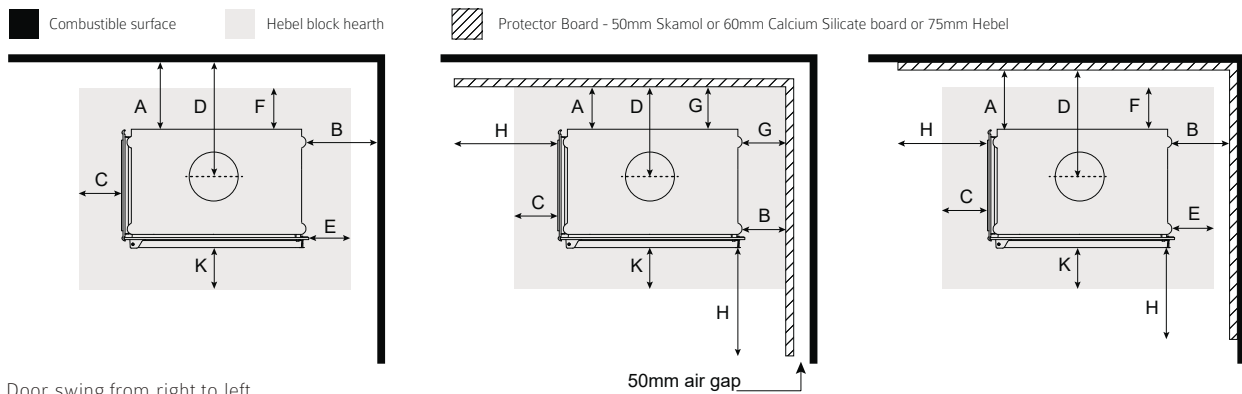

* Door swing from right to left.

*Please note: The above drawings reflect the design of 750 GF2L. Both units share identical dimensions, however the clearance diagram should be mirrored to compensate for the opposing side glass options (left and right).

Crate Size	815 x 630 x 1050	Gross Weight	286 KG	Net Weight	261KG	
				Combustible surface	Protector Board with 50mm air gap	Protector Board attached to the combustibile wall
A	Rear of heater to rear wall	1150	200	400		
B	Side of heater to side wall	875	150	300		
C	Hearth extension from the side glass opening*	400	400	400		
D	Centre of flue to rear wall	1339	389	589		
E	Hearth extension from the side of the heater	200	C & G	200 & C		
F	Hearth extension from the rear of the heater	200	Refer to G dim.	200		
G	Hearth extension towards the Protector Board	N/A	Extend up to the Protector Board	Refer to E & F		
H	Protector Board extension from glass opening	N/A	900	900		
J	Protector Board extension on rear wall	N/A	500	500		
K	Hearth extension from the front glass opening*	700	700	700		
	Protector Board height from hearth	N/A	1900	1900		
	Hearth thickness directly below the appliance	150	150	150		
	Hearth thickness extending beyond the appliance*	50	50	50		

Hearth recommendation:

It is highly recommended that Hebel Block material to be used as the hearth both directly below the appliance and extending beyond the appliance base. Please consult with retailer or installer if you wish to change the hearth material or clearances.

* Please refer to Hearth Clearance document for further information.